



Bobcat®

COMPACT EXCAVATOR E80

Operating Weight	8330 kg
Engine Power	40.4 kW
(Tropical)	39.9 kW
Bucket Capacity	0.28 m ³



One Tough Animal®

E80 — SPECIFICATIONS

Weights

Operating weight (ISO 6016)	8330 kg
Ground pressure with rubber tracks	38.2 kPa

Engine

Make / Model	Yanmar / 4TNV98-ZWDB8 (iT4)
Fuel	Diesel
Number of cylinders	4
Displacement	3.3 L
Maximum power (SAE J1995)	40.4 kW (54.2 HP), Tropical: 39.9 kW (53.5 HP)
Maximum torque (SAE J1995)	248.0 Nm

Performance

Digging force, arm (ISO 6015)	40,900 N
Digging force, long arm (ISO 6015)	34,100 N
Digging force, bucket (ISO 6015)	54,600 N
Drawbar pull	60,800 N
Travel speed (low)	2.9 km/h
Travel speed (high)	4.6 km/h

Hydraulic System

Pump type	One engine-driven tandem axial piston pump and one engine-driven gear pump
Piston pump capacity	144.0 L/min
Auxiliary flow	120.0 L/min
Auxiliary relief	210.0 bar

Swing System

Boom swing (left)	70.0°
Boom swing (right)	55.0°
Swing speed	9.6 RPM

Fluid Capacities

Cooling system	10.0 L
Engine oil and filter	11.6 L
Fuel tank	110.0 L
Hydraulic system	87.0 L

Standard Features

2300 mm dozer blade	Sun visor
450 mm rubber tracks	Electric refueling pump
TOPS/ROPS cab with air conditioner ¹	Auto idle
Fingertip auxiliary hydraulic control	Horn
Control console locks	Work lights
Lockable storage compartment	Retractable seat belt
Deluxe cloth suspension seat	Engine auto shutdown

1. Roll Over Protective Structure (ROPS) – Meets requirements of ISO 3471. Tip Over Protective Structure (TOPS) – Meets requirements of ISO 12117.

Options

Steel Tracks	Rotating beacon
Third auxiliary hydraulic line (clamshell piping)	Quick coupler piping
Boom load holding valve	Long arm
Boom and arm load holding valve	Roof guard

Working Range

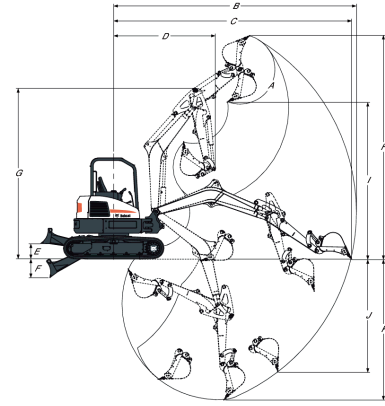

(A)	182.0°	(G)	5019.0 mm
(B)	6965.0 mm	(H)	6715.0 mm
(B*)	7480.0 mm	(H*)	7070.0 mm
(C)	6765.0 mm	(I)	4720.0 mm
(C*)	7295.0 mm	(I*)	5085.0 mm
(D)	2500.0 mm	(J)	3220.0 mm
(D*)	2700.0 mm	(J*)	3730.0 mm
(E)	438.0 mm	(K)	4150.0 mm
(F)	310.0 mm	(K*)	4675.0 mm

* Long arm

Dimensions

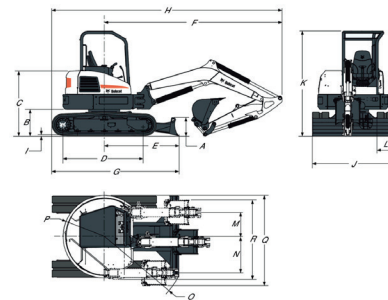

(A)	446.0 mm	(J)	2300.0 mm
(B)	737.0 mm	(K)	2638.0 mm
(C)	1715.0 mm	(L)	450.0 mm
(D)	2200.0 mm	(M)	655.0 mm
(E)	1912.0 mm	(N)	803.0 mm
(F)	4797.0 mm	(O)	2500.0 mm
(G)	2823.0 mm	(P)	1298.0 mm
(H)	6167.0 mm	(Q)	2450.0 mm
(I)	20.0 mm		

DOOSAN

Bobcat is a Doosan Company.

Doosan is a global leader in construction equipment, power & water solutions, engines, and engineering proudly serving customers and communities for more than a century. | Bobcat and the Bobcat logo are registered trademarks of Bobcat Company in the United States and various other countries.
©2020 Bobcat Company. All Rights Reserved.

multico

Asia's Equipment Specialist

Multico Equipment Indonesia, PT.

Plaza Kelapa Gading Blok C No. 12 Jl. Raya Boulevard Barat,

Kelapa Gading, Jakarta Utara, 14240

Phone: +62 21 4585 1122 / Fax : +62 21 2245 5028

www.multicoequipmentid.com

SCAN HERE



Bobcat®

Certain specification(s) are based on engineering calculations and are not actual measurements. Specification(s) are provided for comparison purposes only and are subject to change without notice. Specification(s) for your individual Bobcat equipment will vary based on normal variations in design, manufacturing, operating conditions, and other factors. Pictures of Bobcat units may show other than standard equipment.